



32A		40A		50A		65A		75A		85A	
 <p>See page 28 for more details</p>				 <p>See page 30 for more details</p>							
GMC-32		GMC-40		GMC-50		GMC-65		GMC-75		GMC-85	
GMD-32		GMD-40		GMD-50		GMD-65		GMD-75		GMD-85	
kW	A	kW	A	kW	A	kW	A	kW	A	kW	A
	50		60		80		100		110		135
7.5	32	11	40	15	55	18.5	65	22	75	25	85
15	32	18.5	40	22	50	30	65	37	75	45	85
18.5	28	22	32	30	43	33	60	37	64	45	75
18.5	20	22	23	30	28	33	35	37	42	45	45
hp	A	hp	A	hp	A	hp	A	hp	A	hp	A
	45		50		70		80		90		100
2		3		3		5		5		7.5	
5		5		7.5		10		15		15	
7.5		10		10		15		20		25	
10		10		15		20		25		30	
20		25		30		40		50		50	
20		25		30		40		50		50	
1		1		2		2		2		3	





2-pole Front mount







4-pole Front mount



2-pole Side mount

 <p>See page 40 for more details</p>				 <p>See page 42 for more details</p>							
GMC-32/4		GMC-40/4		GMC-50/4		GMC-65/4		GMC-75/4		GMC-85/4	
GMD-32/4		GMD-40/4		GMD-50/4		GMD-65/4		GMD-75/4		GMD-85/4	
50		60		80		100		110		135	

 <p>Setting ranges (A)</p> <table border="1"> <tr><td>4 - 6</td><td>12 - 18</td></tr> <tr><td>5 - 8</td><td>16 - 22</td></tr> <tr><td>6 - 9</td><td>18 - 26</td></tr> <tr><td>7 - 10</td><td>24 - 36</td></tr> <tr><td>9 - 13</td><td>28 - 40</td></tr> </table> <p>Base for separate mount</p>	4 - 6	12 - 18	5 - 8	16 - 22	6 - 9	18 - 26	7 - 10	24 - 36	9 - 13	28 - 40	 <p>Setting ranges (A)</p> <table border="1"> <tr><td>7 - 10</td><td>28 - 40</td></tr> <tr><td>9 - 13</td><td>34 - 50</td></tr> <tr><td>12 - 18</td><td>45 - 65</td></tr> <tr><td>16 - 22</td><td>54 - 75</td></tr> <tr><td>18 - 26</td><td>63 - 85</td></tr> <tr><td>24 - 36</td><td></td></tr> </table> <p>Base for separate mount</p>	7 - 10	28 - 40	9 - 13	34 - 50	12 - 18	45 - 65	16 - 22	54 - 75	18 - 26	63 - 85	24 - 36	
4 - 6	12 - 18																						
5 - 8	16 - 22																						
6 - 9	18 - 26																						
7 - 10	24 - 36																						
9 - 13	28 - 40																						
7 - 10	28 - 40																						
9 - 13	34 - 50																						
12 - 18	45 - 65																						
16 - 22	54 - 75																						
18 - 26	63 - 85																						
24 - 36																							
<p>GTK-40</p> <p>GTH-40/3</p> <p>GTH-40</p> <p>GTK-40/L</p>	<p>GTK-85</p> <p>GTH-85/3</p> <p>GTH-85</p> <p>GTK-85/L</p>																						
 <p>Setting ranges (A)</p> <table border="1"> <tr><td>4 - 20</td></tr> <tr><td>8 - 40</td></tr> </table> <p>separate mount</p>	4 - 20	8 - 40	 <p>Setting ranges(A) : 16 ~ 80A</p> <p>Separate mount Wiring by screw</p>	 <p>Setting ranges(A) : 5 ~ 60A</p> <p>Separate mount Wiring by CT tunnel</p>																			
4 - 20																							
8 - 40																							

3-pole Contactors / AC coil



- GMC-9
- GMC-12
- GMC-18
- GMC-22

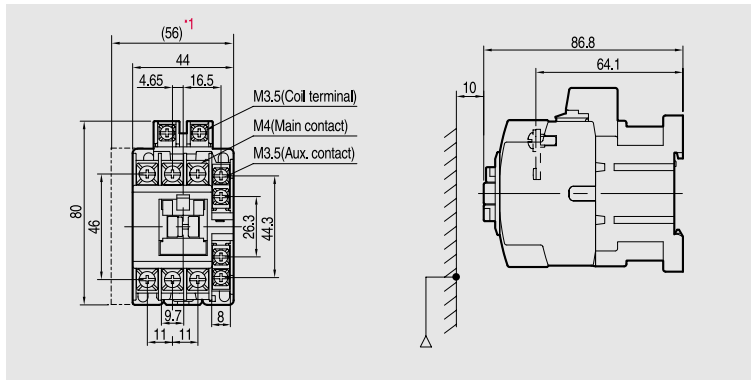

* 1 : Optional auxiliary contact unit (side mount type)

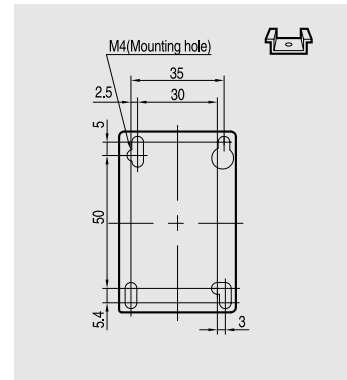

GMC-9,12:0.33kg
GMC-18,22:0.37kg

- GMC-32
- GMC-40

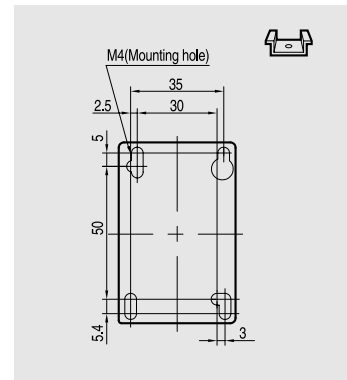
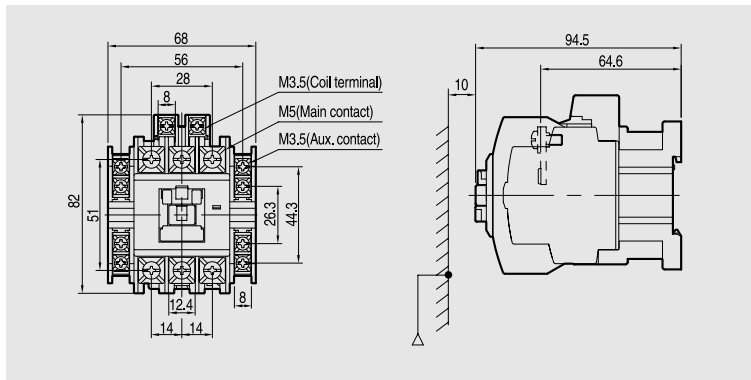

0.45kg

- GMC-50
- GMC-65
- GMC-75
- GMC-85

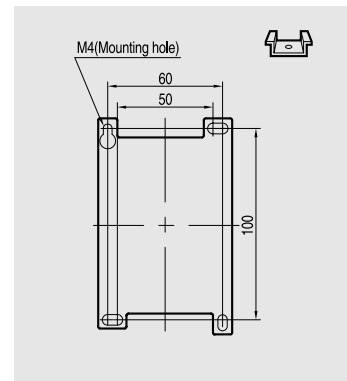
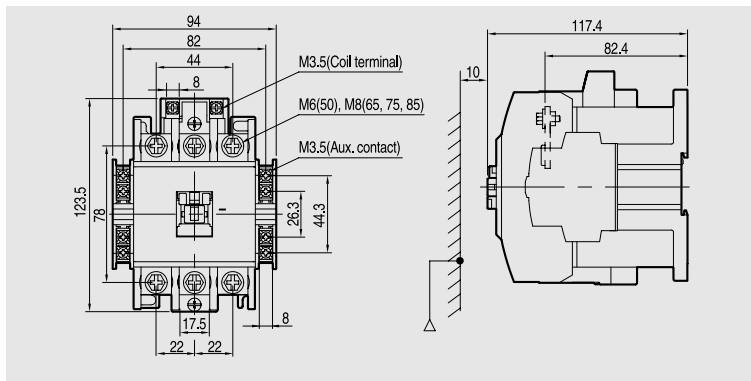

1kg

Circuit diagram

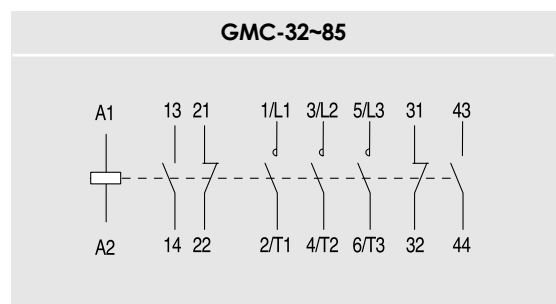
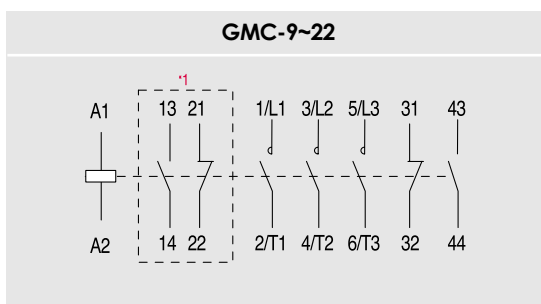

* 1 : Optional auxiliary contact unit