









Quick selection table

Contactors ... 9 to 85A

Frame size		9A	12A	18A	22A
3-pole Contactors					
		See page 26 for more details			
Types	AC coil	GMC-9	GMC-12	GMC-18	GMC-22
	DC coil	GMD-9	GMD-12	GMD-18	GMD-22
Ratings / IEC60947-4		kW	A	kW	A
AC1		25	25	40	40
AC3	200/240V	2.5	11	3.5	13
	380/440V	4	9	5.5	12
	500/550V	4	7	7.5	12
	690V	4	5	7.5	9
Ratings / UL508		hp	A	hp	A
continuous current			20		25
single phase	115V	0.5		1	
	230V	1		3	
three phase	200V	2		5	
	230V	2		5	
	460V	5		10	
	575V	7.5		15	
NEMA size		00		0	
Additional auxiliary contacts		 2-pole Front mount  4-pole Front mount  2-pole Side mount			
		See page 112 for more details			
4-pole Contactors					
		See page 38 for more details		See page 38 for more details	
Types	AC coil	GMC-9/4	GMC-12/4	GMC-18/4	GMC-22/4
	DC coil	GMD-9/4	GMD-12/4	GMD-18/4	GMD-22/4
AC1(A)		20	20	25	32

Overload Relays

Bimetallic style																					
Type GT		See page 77-88 for more details																			
		Setting ranges (A) <table style="display: inline-table; vertical-align: middle;"> <tr><td>0.1 - 0.16</td><td>4 - 6</td></tr> <tr><td>0.16 - 0.25</td><td>5 - 8</td></tr> <tr><td>0.25 - 0.4</td><td>6 - 9</td></tr> <tr><td>0.4 - 0.63</td><td>7 - 10</td></tr> <tr><td>0.63 - 1</td><td>9 - 13</td></tr> <tr><td>1 - 1.6</td><td>12 - 16</td></tr> <tr><td>1.6 - 2.5</td><td>16 - 22</td></tr> <tr><td>2.5 - 4</td><td></td></tr> </table>				0.1 - 0.16	4 - 6	0.16 - 0.25	5 - 8	0.25 - 0.4	6 - 9	0.4 - 0.63	7 - 10	0.63 - 1	9 - 13	1 - 1.6	12 - 16	1.6 - 2.5	16 - 22	2.5 - 4	
0.1 - 0.16	4 - 6																				
0.16 - 0.25	5 - 8																				
0.25 - 0.4	6 - 9																				
0.4 - 0.63	7 - 10																				
0.63 - 1	9 - 13																				
1 - 1.6	12 - 16																				
1.6 - 2.5	16 - 22																				
2.5 - 4																					
		Base for separate mount																			
Class10A	Differential	GTK-22																			
	Non-differential (3-heater)	GTH-22/3																			
	Non-differential (2-heater)	GTH-22																			
Class 20	Differential	GTK-22/L																			
Electronic style																					
Type GMP		See page 98-106 for more details																			
Class 1~30 adjustable		Setting ranges (A) <table style="display: inline-table; vertical-align: middle;"> <tr><td>0.1 - 1.5</td></tr> <tr><td>1 - 5</td></tr> <tr><td>4.4 - 22</td></tr> </table>				0.1 - 1.5	1 - 5	4.4 - 22													
0.1 - 1.5																					
1 - 5																					
4.4 - 22																					
		Separate mount type																			

3-pole Contactors / AC coil



- GMC-9
- GMC-12
- GMC-18
- GMC-22

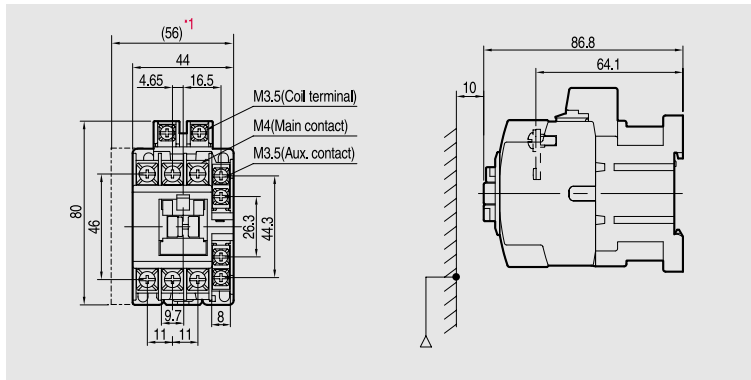

* 1 : Optional auxiliary contact unit (side mount type)

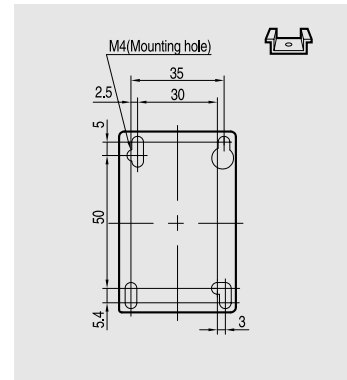

GMC-9,12:0.33kg
GMC-18,22:0.37kg

- GMC-32
- GMC-40

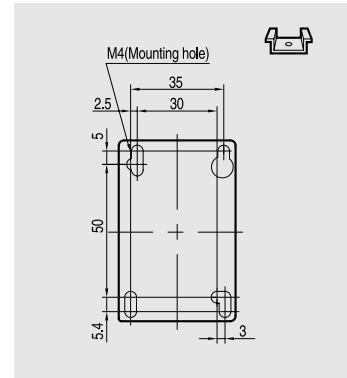
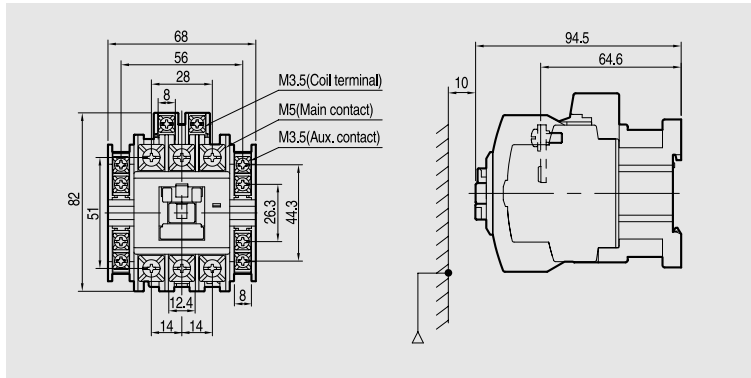

0.45kg

- GMC-50
- GMC-65
- GMC-75
- GMC-85

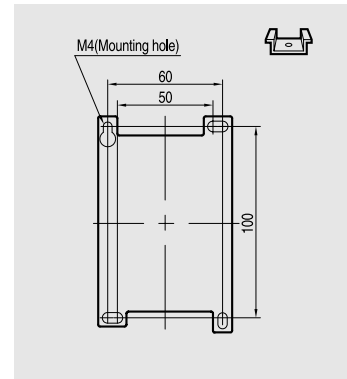
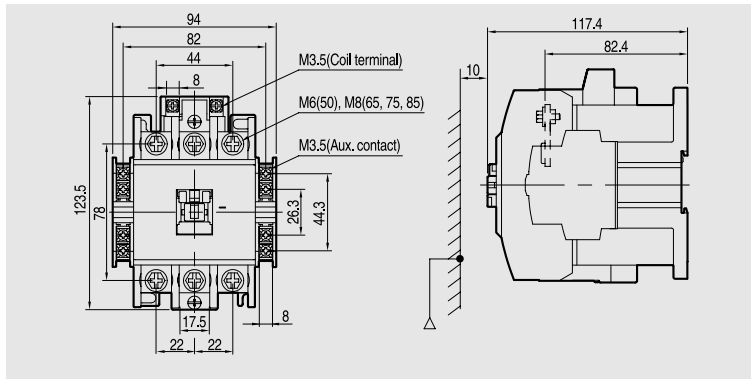

1kg

Circuit diagram

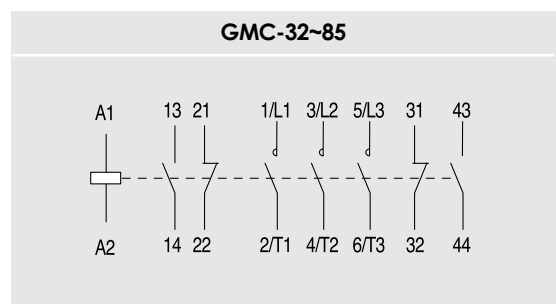
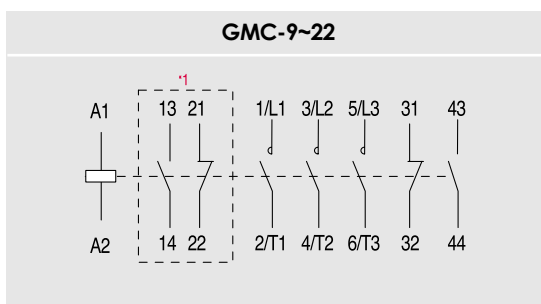

* 1 : Optional auxiliary contact unit